

Cold-rolled sheet piles.

Strong. Efficient. Reliable.

NEW!
KRINGS SECTIONS



KD VI/6
KD VI/8
KD 4L

TKL 3/9

KL 3/4
KL 3/5
KL 3/6
KL 3/7
KL 3/8

HP 290S-5
HP 290S-6
HP 290S-7
HP 290S-8
HP 290S-9

ZK 785-5
ZK 785-6
ZK 785-7
ZK 785-8
ZK 785-9

ZK 675-5
ZK 675-6
ZK 675-7
ZK 675-8
ZK 675-9



UK

A Company
of ThyssenKrupp
Services

ThyssenKrupp GfT Bautechnik



ThyssenKrupp

Cold-rolled sheet piles. Strong. Efficient. Reliable.

From our own cold-rolling mill in Dessau, we supply a market-driven range of trench sheeting and lightweight sections. By taking over Krings in Heinsberg at the end of 2007, we have also optimized our product range by adding HP hat sections and ZK Z-sections.

Serving the construction industry, we develop project-oriented and cost-effective solutions distinguished by quick and punctual delivery and trouble-free installation.

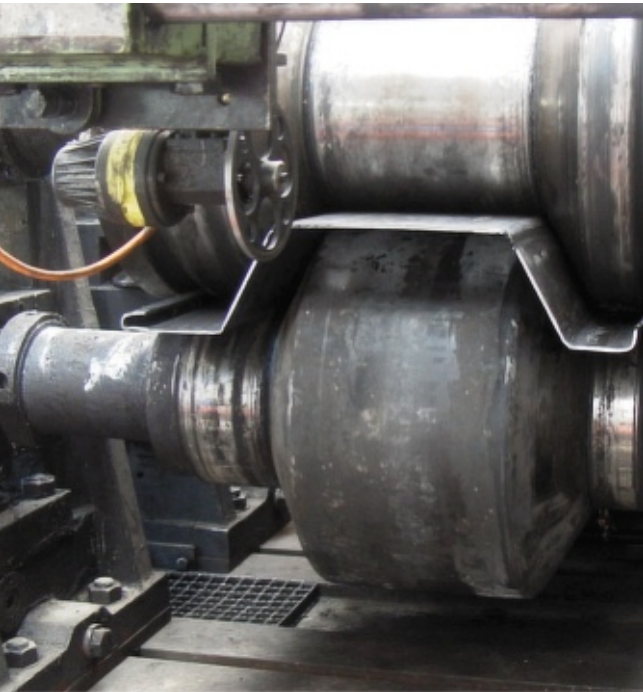

Trench sheeting

Trench sheeting is used for the reliable shoring of trenches, shafts and construction pits. It is always employed in situations where interlock tightness is not an overriding concern.

For pile-driving and technical reasons, a trench sheeting design featuring high dimensional stability has become established, permitting frequent use. Its special shape makes installation more efficient and easier. At our cold-rolling mill, we produce sections of immaculate quality and stock them in lengths of up to 12 m. Longer lengths can be rolled on request.

Lightweight sections

Lightweight sections are mainly used in inner-city trench shoring and for dike rehabilitation. The lightweight section's interlock has shown itself to be a firm hook connection. The sections are produced at the mill in lengths of up to 17 m.

For structures that have to meet high standards of watertightness, e.g. in flood protection, we supply sections with an interlock seal consisting of a permanently elastic bitumen compound. Lightweight sections can also be fitted with the HOESCH profiled interlock sealing system. The sections are subject to DIN-standard materials testing and quality controls and ensure safety and dependability combined with optimum pile-driving properties.

Steel grade for cold-rolled sheet piles conforming to DIN EN 10249-1

Steel grade	Minimum tensile strength N/mm ²	Minimum yield point N/mm ²	Minimum elongation %
S 275 JR	410	275	22

Deviation limits and dimension tolerances for cold-rolled sheet piles made of unalloyed steels to DIN EN 10 249-2

Pile width For single piles $\pm 2\%$; for double piles $\pm 3\%$.

Pile length Pile length may deviate by ± 50 mm from the ordered length.

Weight The deviation between the arithmetic weight (as given in the table of sections) and actual weight of the total consignment is max. $\pm 7\%$.

Trench sheeting. Technical details.



Section	Modulus of section		Weight		Second moment of area	Section width	Wall height	Back thickness	Web thickness
	W_y								
	cm^3/m	kg/m^2	kg/m		l_y	b	h	t	s
	Wall	Wall	Single pile	Wall	cm^4/m	mm	mm	mm	mm
KD VI/6 ²⁾	182	62.5	37.5	726		600	78	6.0	
KD VI/8 ²⁾	242	83.3	50.0	968		600	80	8.0	
KD 4L ¹⁾	99	53.3	21.3	245		400	49	5.8	

Available lengths up to 12 m (from 12 to 14 m available on request)

¹⁾ Warehouse lengths from 3 to 6 m

²⁾ Warehouse lengths from 3 to 8 m

The basis for billing is the weight of the single pile (kg/m).

KD VI/6 and KD VI/8

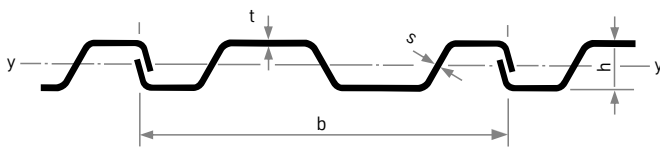

KD 4L

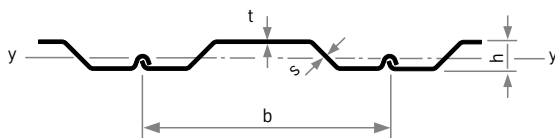

Handling holes in trench sheeting KD VI/6 and KD VI/8

View A

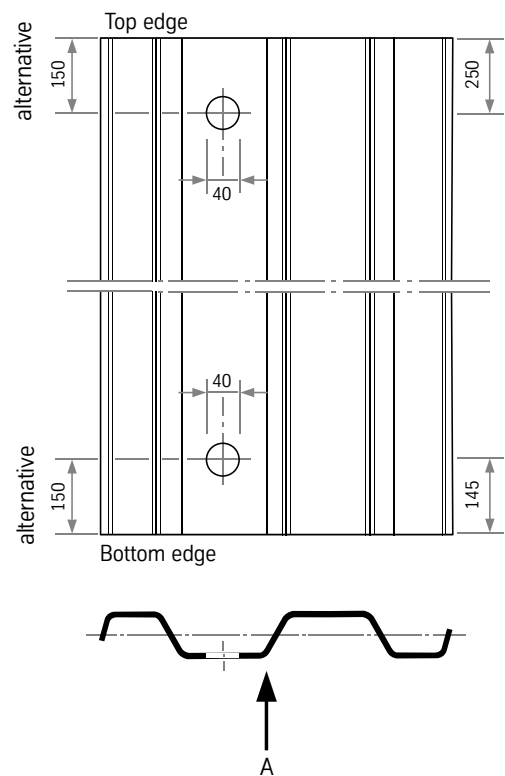

Available trench sheeting

E

KD VI/6
KD VI/8

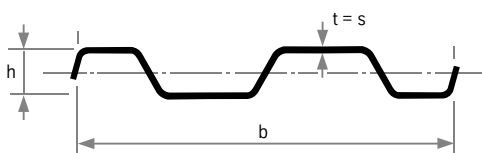

E

KD 4L

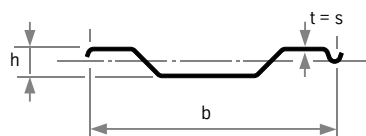

Trench sheeting is only supplied in single piles.

Handling holes in trench sheeting KD 4L

The holes are applied at both ends, as shown in the figure.

Lightweight sections. Technical details.



Section	Modulus of section W_y cm ³ /m	Weight		Second moment of area I_y cm ⁴ /m	Section width b mm	Wall height h mm	Back thickness t mm	Web thickness s mm
		kg/m ² Wall	kg/m Single pile					
KL 3/4*	276	45.2	31.6	2042	700	146	4.0	
KL 3/5*	339	55.8	39.1	2502	700	147	5.0	
KL 3/6	410	66.0	46.2	3080	700	148	6.0	
KL 3/7*	460	78.0	54.6	3500	700	149	7.0	
KL 3/8	540	88.0	61.5	4050	700	150	8.0	
TKL 3/9	680	106.9	74.8	5120	700	160	9.0	
HP 290S-5	774	69.7	49.5	10920	710	294	5.0	
HP 290S-6	933	83.7	59.4	13530	710	296	6.0	
HP 290S-7	1080	97.6	69.3	15701	710	298	7.0	
HP 290S-8	1230	111.5	79.2	17896	710	300	8.0	
HP 290S-9	1380	125.6	89.2	20896	710	300	9.0	
ZK 785-5	605	53.4	41.9	8395	785	276	5.0	
ZK 785-6	724	64.2	50.4	10053	785	277	6.0	
ZK 785-7	836	74.4	58.4	11657	785	278	7.0	
ZK 785-8	951	84.8	66.6	13302	785	279	8.0	
ZK 785-9	1067	95.3	74.8	14944	785	280	9.0	
ZK 675-5	972	62.1	41.9	18500	675	376	5.0	
ZK 675-6	1164	74.7	50.4	22131	675	377	6.0	
ZK 675-7	1350	86.5	58.4	25698	675	378	7.0	
ZK 675-8	1540	98.7	66.6	29332	675	379	8.0	
ZK 675-9	1728	110.8	74.8	32914	675	380	9.0	

KL 3/4 to KL 3/8 and TKL 3/9 | Available lengths up to 12 m (12 to 14 m available on request) | Warehouse lengths from 3 to 8 m
 HP 290S-5 to HP 290S-9 | Available lengths up to 17 m | Warehouse lengths from 8 to 12 m
 ZK 785-5 to ZK 785-9 and ZK 675-5 to ZK 675-9 | Available lengths up to 12 m

*No section available ex stock

The basis for billing is the weight of the single pile (kg/m).

KL 3/4 to KL 3/8

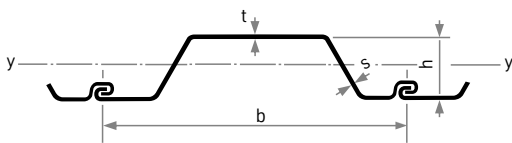

ZK 785-5 to ZK 785-9

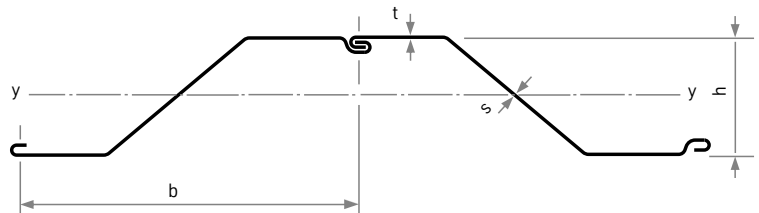

TKL 3/9

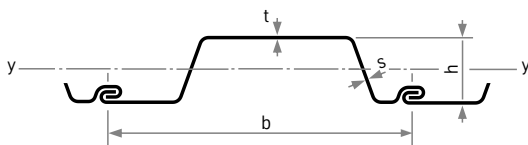

ZK 675-5 to ZK 675-9

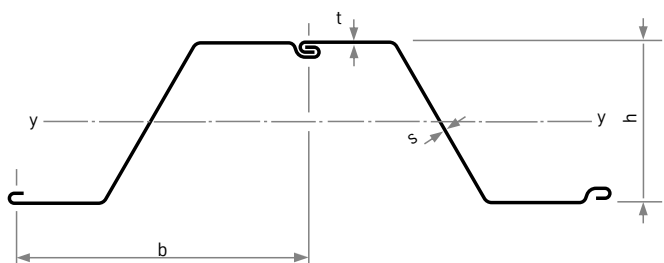

HP 290S-5 to HP 290S-9

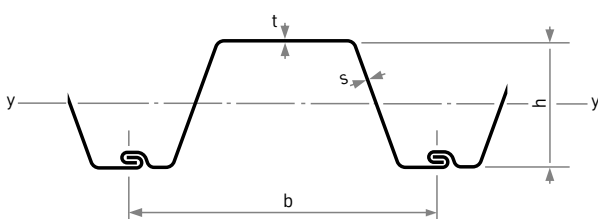



Available KL, TKL and HP lightweight sections

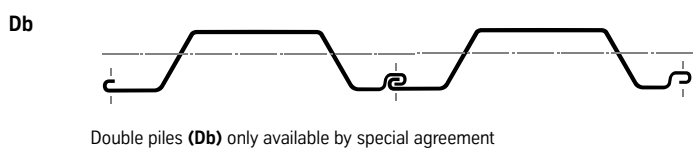
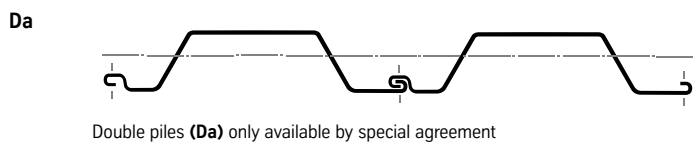
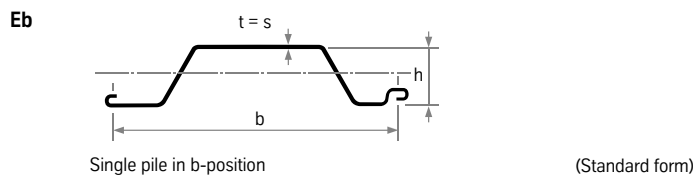
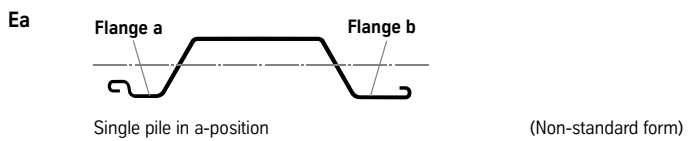

Available ZK lightweight sections

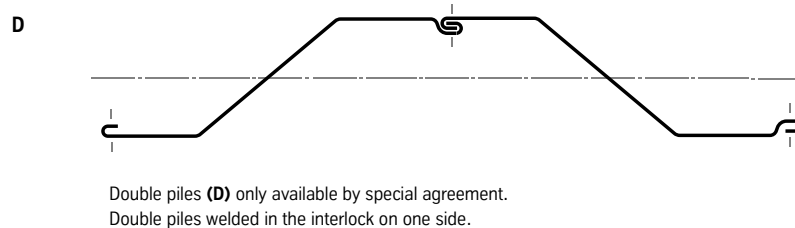
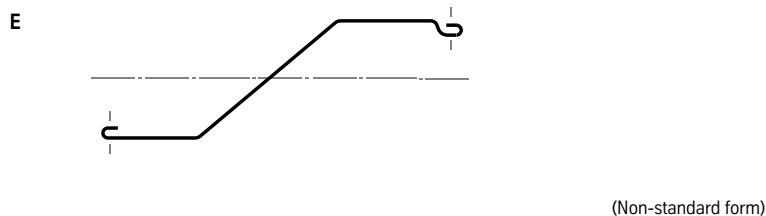

Handling holes of KL, TKL and HP lightweight sections

The KL, TKL and HP lightweight sections are supplied with handling holes. The holes are applied at both ends, as shown in the figure.

View B

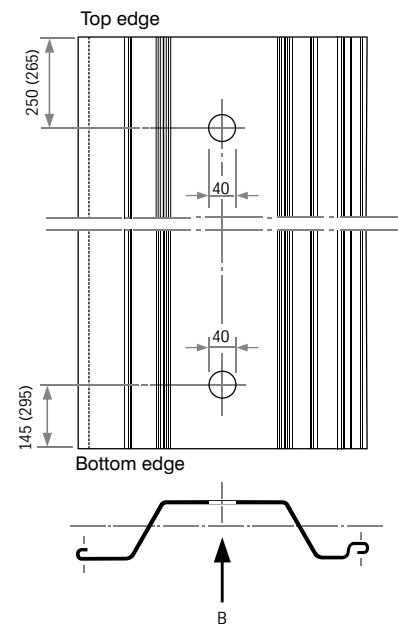

a-position

Handling hole	145 mm from Top edge	non-standard form
KL-profile	250 mm from Bottom edge	form
Handling hole HP-	265 mm from Top edge	standard form
and TKL-profile	295 mm from Bottom edge	form

b-position

Handling hole	250 mm from Top edge	standard form
KL-profile	145 mm from Bottom edge	form
Handling hole HP	295 mm from Top edge	non-standard form
and TKL-profile	265 mm from Bottom edge	form

ZK lightweight sections

are supplied without handling holes.

Welding of ZK lightweight sections

Double piles, which we only supply by special agreement, can be welded in the interlock on one side at the top, bottom or in the middle of the pile.

The weld seam at the top and bottom is 15 cm long in each case.

Other seams are 10 cm long and welded at intervals of 1.5 m.

Lightweight sections. Wall and Krings corner sections.

Corner piles with V 20 Wall sections

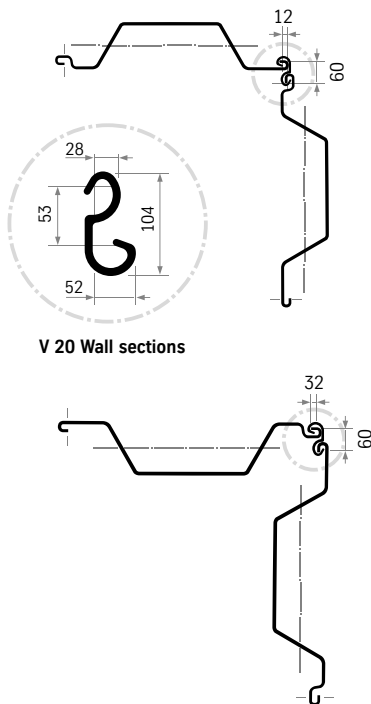

V 20 Wall sections

Corner piles with Krings KEP 90 corner sections

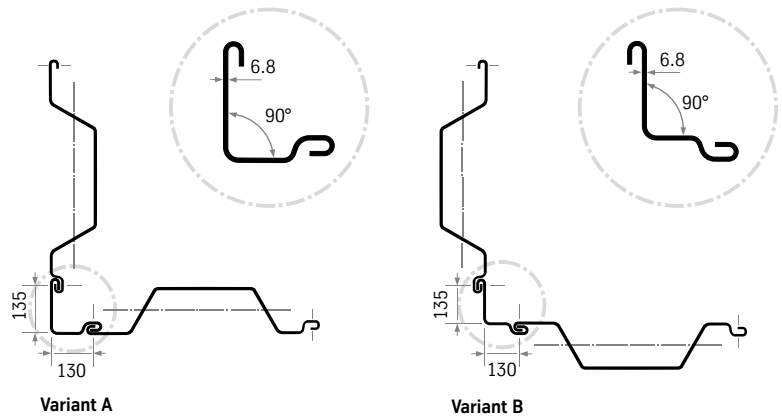

Variant A

Variant B

Krings KEP corner sections are available in variants A and B with a 90° angle. -20° and +20° angle variation is possible within the interlock and ±10° in the hook. This means that variant A has a total angle range of 80 to 120° and variant B 60 to 100°.

Further variants are available on request.

Interlock seals.

Interlocks with bitumen seals applied in the factory or on site.

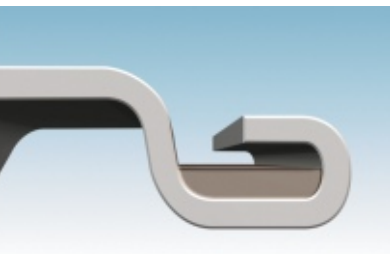

SIRO 88

By filling the threading interlock with bituminous materials before driving, it is possible to reduce the interlock's water permeability considerably. Bitumen-based sealing materials can be applied to lightweight section interlocks in the factory or on the construction site.

SIRO 88 is a bituminous hot-sealing compound suitable for vibratory driving. For percussive driving, bituminous putty is recommended. The direction of driving has to be decided before sealant-filled piles are installed. Piles filled with bitumen putty should preferably be percussively driven. When positioning double piles on site, care must be taken to ensure that the filled interlock is driven first and then the free interlock.

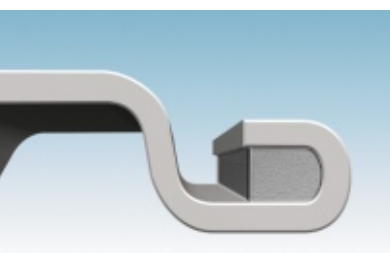

Bitumen sealing compound

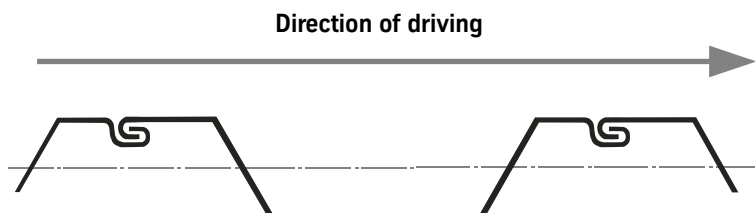

HOESCH interlock sealing system. (DBP 44 27 561; EP 0 695 832).

The HOESCH interlock sealing system is factory-fitted in sheet pile interlocks. It consists of a machine-profiled seal in the threading interlock. Treatment with an appropriate primer ensures excellent adhesion in the interlock and prevents rusting underneath the seal.

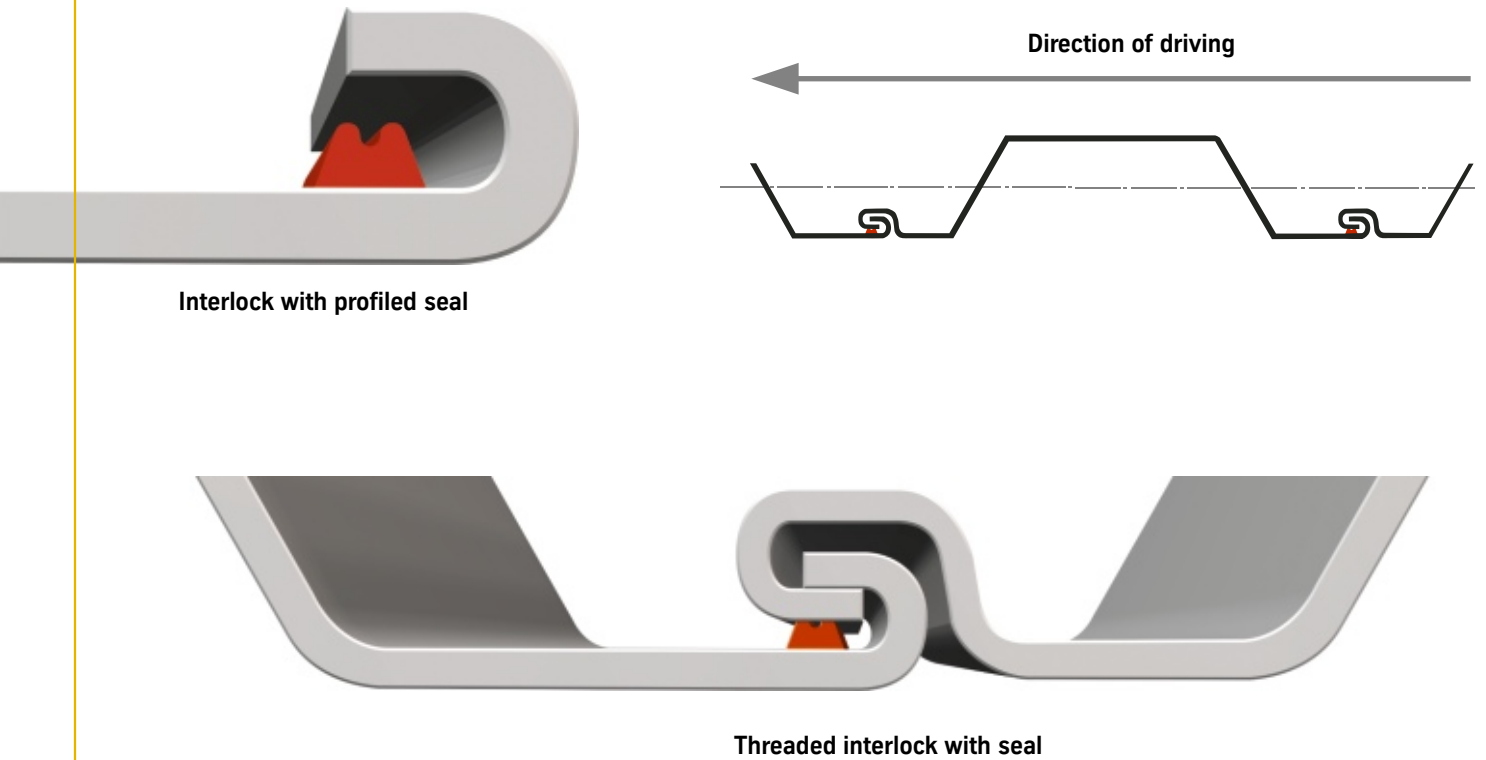

Direction of driving.

When using sealed piles, the direction of driving must be decided on before installation. When positioning double piles on site, care must be taken that the free interlock is driven first and the interlock with the seal is then threaded in.

For threading, the pile must therefore be turned so that the unsealed interlock is pointing in the direction of driving.

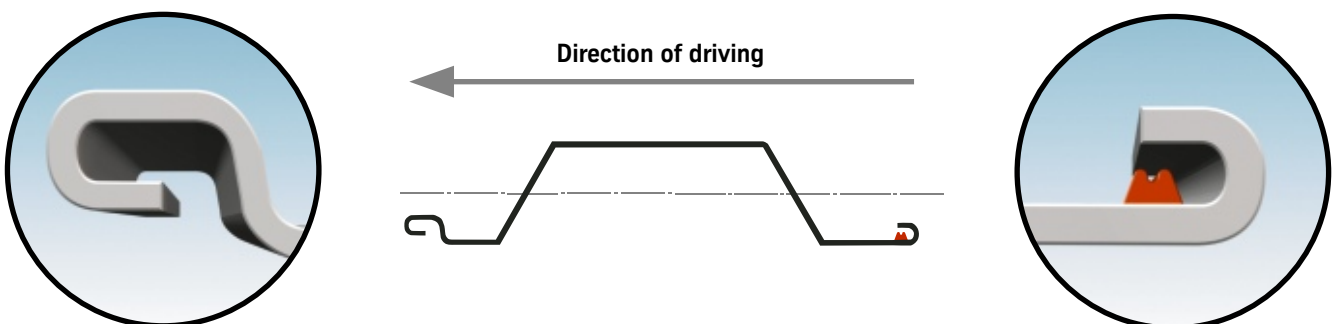

ThyssenKrupp GfT Bautechnik GmbH

P.O. Box 10 22 53, 45022 Essen, Germany
Altendorfer Strasse 120, 45143 Essen, Germany
Phone: +49 201 188-2313
Fax: +49 201 188-2333
bautechnik@thyssenkrupp.com
www.tkgftbautechnik.com

Export

Altendorfer Strasse 120, 45143 Essen, Germany
Phone: +49 201 188-3991
Fax: +49 201 188-3974
export-bautechnik@thyssenkrupp.com

Eastern Europe

Altendorfer Strasse 120, 45143 Essen, Germany
Phone: +49 201 188-2703
Fax: +49 201 188-3958
osteuropa-bautechnik@thyssenkrupp.com

Represented by: